

2-STAGE SIDEKICK TORQUE REACTION ARMS

MOUNTS ON ANY NASCO TOOL SUPPORT. UNEXCELLED MOUNTING FLEXIBILITY TO SATISFY ALL ASSEMBLY REQUIREMENTS AND CONSTRAINTS. NO TORQUE REACTION 0 TO 200 IN.-LBS.

2-STAGE SIDEKICK

Mounts instantly on any Nasco tool support. Easy to assemble-no tools required. Telescoping unit provides complete freedom of movement. System includes adjustable post clamp, swivel air manifold, 1/4" by 1/4" and 1/4" by 1/8" NPT steel nipples for air tool hook-up, 1/4" plugs, bale and 2-stage Telescoping Torque Reaction Arm.

SPECIFICATIONS

Model	Standard Duty Tool Supports B1 & B2 Series	Reach	
		Min.	Max.
SK-18	18" boom	17"	25"
SK-24	24" boom	22"	37"
SK-30	30" boom	28"	49"

Heavy Duty Tool Supports BH and FH Series

HSK-24	24" boom	21"	37"
HSK-36	36" boom	27"	50"

Note: Reach may vary slightly due to air tool size. Minimum and maximum reach may be increased or decreased by resetting position of clamp.

B1SK-2-18,* 24* OR 30*

All units include B1-S tool support with swivel boom, 2-5 lb. balancer, 1/4" x 6ft. long air hose, air hose clamp, bench mounting screws and 2-Stage Telescoping Torque Reaction Arm. -E models for electric tools includes a SK-ETM electric tool mount and eliminates the air accessories.

** Designates boom length and matching 2-Stage Sidekick.*

Add suffix -E for electric tools.

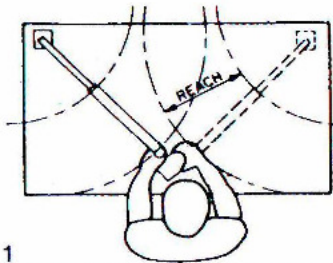

Figure 1
For maximum reach use longest boom and Sidekick

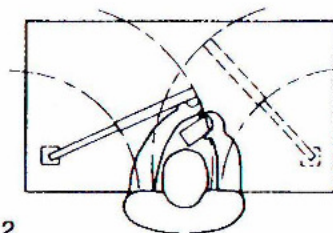

Figure 2
Downward view of workstation showing possible mounting

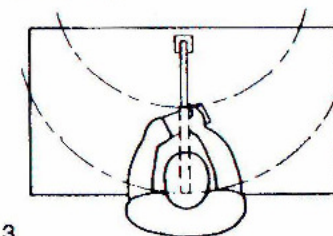

Figure 3
Typical mounting location

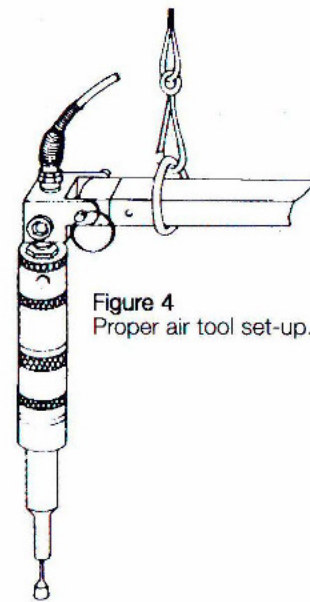
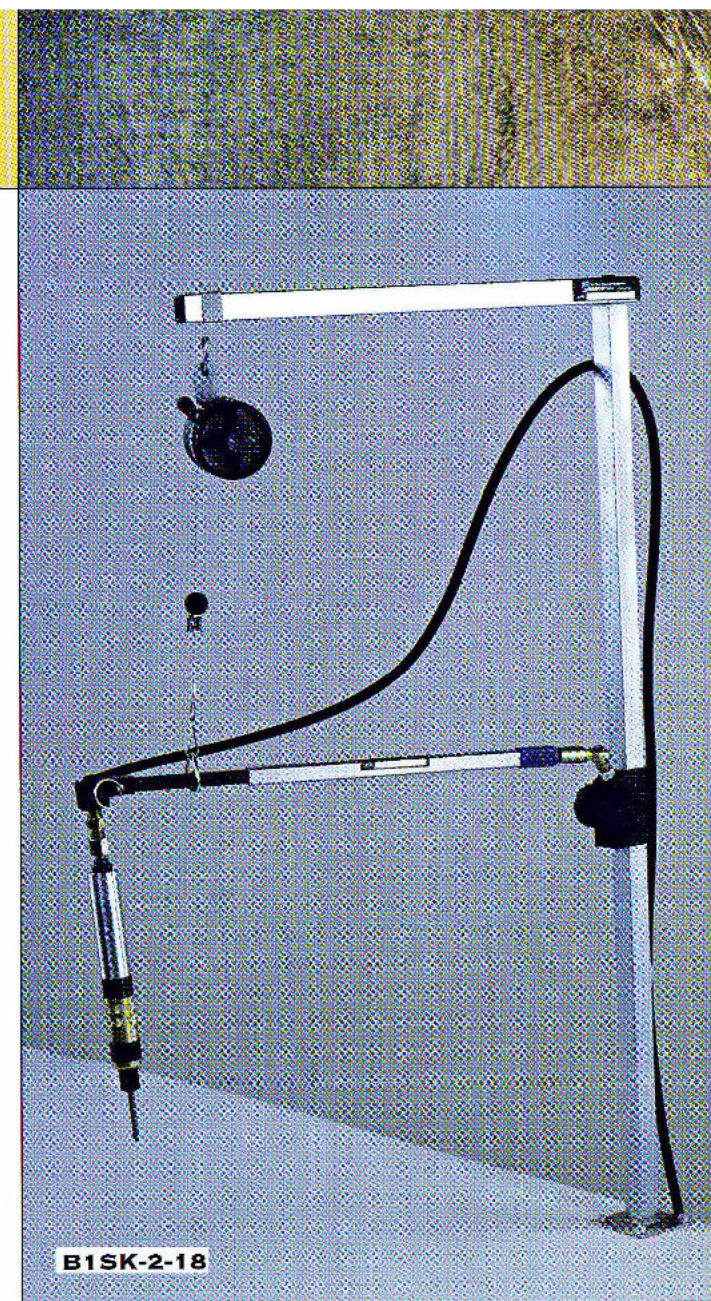

Figure 4
Proper air tool set-up.



B1SK-2-18